



Eaton Micro Data Center



Powering Business Worldwide

Pain Points for Building Data Centers



- Managing the project within the budget and schedule
- Seamless integration of data center components
- Vendor neutral software providing a holistic view of the state of the data center
- Reducing the manual work of data center managers
- Standardized facility processes and audits across multiple facilities
- Reducing operating expenses especially for cooling, power & space
- Data segregation between facility and IT

Eaton MDC : One Solution for all Pain Points

Why Eaton MDC Solution is better than others?

Bundled with a fully featured DCIM

Customize MDC to fit every budget and application

Advanced asset management and rack building tools

PUE of 1.4 against industry average of 2.3*

Separate cable channel to isolate MDC cables from user cables

Capacity management including power usage, ports (network and power) and U Space

Comprehensive service support across India

Inbuilt branch circuit monitoring

Programmable emergency operations module

Monitor multiple MDCs from a single interface

Single Rack MDC : MDC Components

SENSORS

Temperature, Humidity, Smoke, WLD, Electronic Lock



LIGHTING



PDU

Power Distribution Unit



CCTV



FIRE

In-rack Fire Suppression Unit

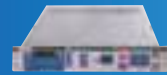

PDM

Power Distribution Module



UPS

Uninterrupted Power System

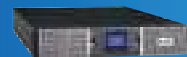

COOLING 3.5kW/7kW

Inverter Compression Driven



Single Rack : Features



Build Quality

- IP50 protection
- Side walls panelled with insulation
- Made in India

Precision Cooling

- Fully inverter based cooling
- R410A environment friendly refrigerant
- Long life compressor

Power Quality & Distribution

- Industry's first intelligent Power Distribution Module (PDM)
- Ability to position UPS inside or outside the rack

Security & Safety

- Option of emergency back door opening or secure ventilation system
- Inbuilt fire suppression unit

The Power of **EAT•N** DCIM

Monitoring
& Alarm Management

PUE, Capacity &
Asset Management

Data Access &
Reporting

Eaton Bundled DCIM Solution

Visual Capacity 
Optimization Manager

Intelligent management through VCOM

MANAGE

Pure Facility & IT Asset Management Features

REPORTS



MONITOR

Data Collection with Alarms, Notifications, Dashboards & Trend Charts

WORKFLOW

Projects, Tasks & Work Orders, Automate change requests

VCOM Key Resources Managed



POWER

- Power capacity and utilization
- Run rates and resource exhaustion
- Cross charging and billing



SPACE

- Floorplan usage and analysis
- Rack space utilization and reservations
- Power | Network port utilization



COOLING

- Cooling infrastructure capacity and utilization
- Cooling related cost tracking
- Thermal imaging views and history



IT DEVICES

- Rackmount devices (server, switch, chassis, Rack PDU, Rack UPS)
- Environmental sensors (temperature, humidity, contacts)



FACILITY

- Power delivery (switchgear, generator, transfer switch, UPS, PDU, RPP, Power Bus)
- Cooling infrastructure (chiller, CRAC, CRAH, in-row cooling)



SECURITY

- Cameras with streaming video views
- Electronic rack locks with mobile unlock features
- Access control system integrations

Most Used Features of DCIM



Command & Control



Tracking PUE



Environmental Monitoring



Root Cause/Impact Analysis



Self-service Setup



Dashboard & Reports

Eaton Smart Power Distribution Module (PDM) *With In-Built Branch Circuit Monitoring*

- Rack mount occupies 3U space
- Monitors electrical parameters at each breaker
- Eliminates the need for iPDU

Models Available	
7	
A	Basic - Single Incomer with Single UPS
B	Basic - Single Incomer with Redundant UPS
C	Basic - Dual Incomer with Redundant UPS
D	Metered - Single Incomer with Single UPS
E	Metered - Single Incomer with Redundant UPS
F	Metered - Dual Incomer with Redundant UPS

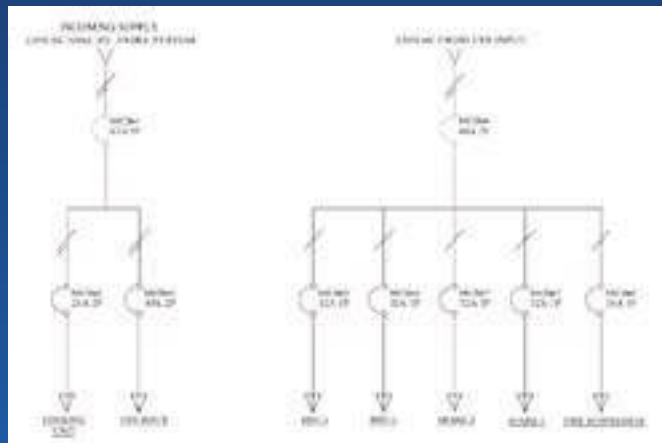

Precision Cooling : Features

- 3.5kW and 7kW In-rack cooling system
- 7KW In-row cooling system also available
- Fully inverter based cooling for more efficiency and longer life
- R410a environment-friendly refrigerant
- Fan speed modulation based on real time heat load
- Optional humidity control available
- Up to 15m copper piping support
- Maintenance downtimes avoided as cooling controllers are placed outside the rack

ONE OF OUR CORE GOALS IS TO SAVE ENERGY AND REDUCE OUR CARBON FOOTPRINT



30 - 35% Reduction in Carbon Footprint against Conventional DC Solution

Eaton MDC : Energy Saving

Eaton MDC: Energy Saving

- In-rack cooling cools the heat source closely and directly
- Pre-designed Hot/Cold Aisle to optimize the airflow and eliminate cooling loss
- PUE* as low as 1.4 (Versus traditional PUE = 2.2~3)

Assuming 7kW IT Load

- 1 Traditional Server Room power consumption : 7kw x 2,2 = 15,4kw
- 2 Eaton MDC : 7kw x 1,4 = 9,08kw

Energy Saving (1) – (2) = 5.6kW

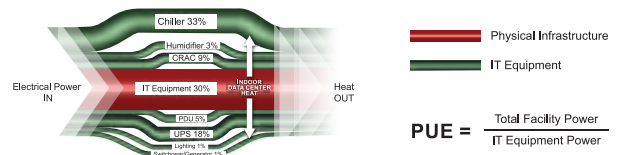

* PUE or Power Usage Effectiveness refers to a way to benchmark datacenter's energy efficiency

Value	Assuming Cost Saving	Unit Cost	kWh	Cost Saving
Energy Saving during 3 years	5.6kw X 24hrs X 365 days X 3 years = 147168kWh			
Energy Charge Rate	1kWh = 8Rs	1	147168	1177344 Rs
			Total cost	1177344 Rs

CO2 Reduction : 0.424kg / kWh

147168kWh*0,424 kg = 62400kg = 62.4Tons

Enabled by Multiple Sensors



3 Zone Temperature & Humidity



Water Leakage Detection



CCTV with ITB NVR



Biometric Access



Smoke Detection



Indicator lights with Beacon Alarm

For Eaton MDCs, we provide our customers various configuration options as per their requirements.

Configured MDC with Part Code Details

MDC Part Code : **MDCBBABDAABABBABA**

M	Micro data center
D	42U - 800 x 1200
C	High Temperature Emergency Back door opening
B	Front Fingerprint Locking system
B	CCTV Camera with 1 TB NVR (Upto 4 Cameras)
A	No Beacon Alarm
B	Indicator Lights with Beacon Alarm
D	Metered - Single Incomer with Single UPS
A	IEC Basic
A	IEC 32A PDU 0 U with Digital LCD Meter and 28 outlets (24 C13 + 4 C19 Outlets) with 1.5 Meter Input Cable (Meter displaying V A T & Rh) with 1.5 Meter hardwired input cable
B	Rack mounted Fire detection with FK-5-1-12 suppression
A	3.5KW - Full Inverter Rack Mount
B	Cold Aisle - 3 Point Temperature Sensor with Front Panel display + Humidity Sensor
B	Rope Water Leakage sensor with display
A	Gateway
B	Rodent Repellent system
A	VCOM

EAT•N MDC ROI :
The only MDC that facilitates -

**Quick
Standardized
Deployments**

**Single -
Dashboard
Monitoring**

**Reduced
Cooling
Cost**

**Reduced
Carbon
Footprint**

**Customized
sizes & features
as per budget**

Single Rack Micro Data Center

Technical Specifications				
Svstem Size (W X D X H) in MM	800 x 27U x 1200	600 x 42U x 1200	800 x 42U x 1200	800 x 45U x 1200
Power Input	220/230/240Vac, 50/60Hz, 1Ph+N+PE			
Enclosure Type	Enclosed cold and hot aisle. Glass front door + solid metal rear Double door			
Emergency Ventilation system	1. Secured Emergency ventilation on Rear Door during cooling Failure 2. Emergency Auto door opening system during cooling Feature			
Color	RAL 9005			
UPS rating	3kVA/6kVA/10kVA			
Recommended IT load	2 KW to 7kW			
Cooling Unit	3.5kW/7kW Rack Mountable Indoor Unit and Condenser Unit with Inbuilt Inverter based Rotary Compressor			
Copper Piping Distance	Maximum 15 Meter (Max vertical Head 6 Meter, Vertical down 3 Meter)			
Access control System	Front 3 Point Locking system / Front and Rear 3 Point Locking system / Front Fingerprint Locking system/ Front and Rear Finger print Locking system			
Power Distribution	Basic / Metered Intelligent Power Distributions Modules for the measurement of Voltage, Current , THDi and the Power Options:			
	Basic - Single Incomer with Single UPS			
	Basic - Single Incomer with Redundant UPS			
	Basic - Dual Incomer with Redundant UPS			
	Metered - Single Incomer with Single UPS			
	Metered - Single Incomer with Redundant UPS			
	Metered - Dual Incomer with Redundant UPS			
Available U space w/o UPS with Fire Suppression and PDM	18U/3.5kW	32U/3.5kW, 30U /7kW	32U/3.5kW ,30U /7kW	
Available U space with UPS with Fire Suppression and PDM	15U/3.5kW	30U/3.5kW, 28U /7kW	30U/3.5kW ,28U /7kW	
Cooling	3.5kW/7kW Inverter based 4U/6U Height Airconditioned Unit			
PDU outlets	B-PDU,1U C13 x 12,16A 1P 230/230V	IEC 32A PDU 0 U with Digital LCD Meter and 28 outlets (24 C13 + 4 C19 Outlets)		
Gateway	Transparent Gateway for the Modbus over TCP IP Connectivity.			
Monitoring Software	Intelligent Management through VCOM(DCIM) with the following Features: <ul style="list-style-type: none"> • Monitor through Data Collection with alarms and Notifications, Dashboards and Trend Charts. • Manage Facility and IT Asset management Features. • Workflow through Project, tasks and Work Orders and automate the change Request. • Reports Creation on PDF formats on Weekly, Monthly or annual basis for the Various Parameters. 			
Connectivity	HTTP (Modbus & SNMP)			
Sensors	3 x Temperature, 1 x Humidity, 1 x Smoke Sensor			
Fire system	2U Fire Detection and suppression system based on Novec 1230			
CCTV system	CCTV system with 1TB Hard Disk			
Water Leakage Detection system	Water Leakage Detection system in order to identify the Water leakage inside the cabinets.			
Rodent repellent system	Rodent repellent system with 2 Transducer			
Beacon Alarm	Indicator Light with Beacon for the Alarm			
Alarm Lights	Alarm Lights on the Cold Aisle with Red and Blue Indication for the Alarm / No Alarm Indication			
Options	ATS/ intelligent PDU...etc			
Weight	250KG	400KG	450KG	500KG

Micro Data Center with Inrow addition

Technical Specifications				
System Size (W X D X H) in MM	600 x 42U x 1400	800 x 42U x 1400	600 x 42U x 1400 (2 racks)	800 x 42U x 1400 (2 racks)
Power Input	220/230/240Vac, 50/60Hz, 1Ph+N+PE			
Dimensions of the Cooling Unit	200mm Width x 2100mm Height x 1400mm Depth			
Enclosure Type	Enclosed cold and hot aisle. Glass front door + solid metal rear Double door			
Emergency Ventilation system	1. Secured Emergency ventilation on Rear Door during cooling Failure 2. Emergency Auto door opening system during cooling Feature			
Color	RAL 9005			
UPS rating	3kVA/6kVA/10kVA			
Recommended IT load	2 KW to 7KW			
Cooling Unit	7kW Inrow Unit with Outdoor Unit with Inbuilt Inverter based Rotary Compressor			
Copper Piping Distance	Maximum 15 Meter (Max vertical Head 6 Meter, Vertical down 3 Meter)			
Access control System	Front 3 Point Locking system / Front and Rear 3 Point Locking system / Front Fingerprint Locking system/ Front and Rear Finger print Locking system			
Power Distribution	Basic / Metered Intelligent Power Distributions Modules for the measurement of Voltage, Current , THDi and the Power Options:			
	Basic - Single Incomer with Single UPS			
	Basic - Single Incomer with Redundant UPS			
	Basic - Dual Incomer with Redundant UPS			
	Metered - Single Incomer with Single UPS			
	Metered - Single Incomer with Redundant UPS			
	Metered - Dual Incomer with Redundant UPS			
Available U space w/o UPS with Fire Suppression and PDM	37U	37U	77U	77U
Available U space with UPS with Fire Suppression and PDM	34U	34U	74U	74U
Cooling	7kW Inrow based inverter based Airconditioned Unit			
PDU outlets	B-PDU,1U C13 x 12,16A 1P 230/230V	IEC 32A PDU 0 U with Digital LCD Meter and 28 outlets (24 C13 + 4 C19 Outlets)		
Gateway	Transparent Gateway for the Modbus over TCP IP Connectivity.			
Monitoring Software	Intelligent Management through VCOM(DCIM) with the following Features. <ul style="list-style-type: none"> • Monitor through Data Collection with alarms and Notifications, Dashboards and Trend Charts. • Manage Facility and IT Asset management Features. • Workflow through Project, tasks and Work Orders and automate the change Request. • Reports Creation on PDF formats on Weekly, Monthly or annual basis for the Various Parameters. 			
Connectivity	HTTP (Modbus & SNMP)			
Sensors	3 x Temperature, 1 x Humidity, 1 x Smoke Sensor			
Fire system	2U Fire Detection and suppression system based on Novec 1230			
CCTV system	CCTV system with 1TB Hard Disk			
Water Leakage Detection system	Water Leakage Detection system in order to identify the Water leakage inside the cabinets.			
Rodent repellent system	Rodent repellent system with 2 Transducer	Rodent repellent system with Transducer		
Beacon Alarm	Indicator Light with Beacon for the Alarm			
Alarm Lights	Alarm Lights on the Cold Aisle with Red and Blue Indication for the Alarm / No Alarm Indication			
Maximum Depth of Servers and storages to be added	Max of 940mm Depth Servers and storages can be added based on power Requirements.			
Weight of the Rack	250KG	400KG	450KG	500KG
Weight of the Cooling Unit	200KG			
Options	ATS / intelligent PDU... etc			

Single Rack Micro Data Center with Panel cooling Option

Technical Specifications		
System Size (W X D X H) in MM	600 x18U x 600	600 x 27U x 1000
Power Input	220/230/240Vac, 50/60Hz, 1Ph+N+PE	
Enclosure Type	Enclosed cold and hot aisle. Glass front door + solid metal rear Double door	
Emergency Ventilation system	1. Secured Emergency ventilation on Rear Door during cooling Failure 2. Emergency Auto door opening system during cooling Feature	
Color	RAL 9005	
UPS rating	3kVA/6kVA/10kVA	
Recommended IT load	2 KW to 7KW	
Cooling Unit	700 Watts side mountable type Panel Cooling unit 700 Watts/1630 Watts side mountable type Panel Cooling unit	
Access control System	Front 3 Point Locking system / Front and Rear 3 Point Locking system / Front Fingerprint Locking system/ Front and Rear Finger print Locking system	
Power Distribution	Basic / Metered Intelligent Power Distributions Modules for the measurement of Voltage, Current , THDi and the Power Options:	
	Basic - Single Incomer with Single UPS	
	Basic - Single Incomer with Redundant UPS	
	Basic - Dual Incomer with Redundant UPS	
	Metered - Single Incomer with Single UPS	
	Metered - Single Incomer with Redundant UPS	
	Metered - Dual Incomer with Redundant UPS	
Available U space w/o UPS with Fire Suppression and PDM	12U	22U
Available U space with UPS with Fire Suppression and PDM	9U	19U
Cooling	Panel Cooling unit 700Watts w/o Outdoor Unit	Panel Cooling unit 700Watts/1630Watts w/o Outdoor Unit
PDU outlets	B-PDU,1U C13 x 12,16A 1P 230/230V	
Gateway	Transparent Gateway for the Modbus over TCP IP Connectivity.	
Monitoring Software	Intelligent Management through VCOM(DCIM) with the following Features. <ul style="list-style-type: none"> • Monitor through Data Collection with alarms and Notifications, Dashboards and Trend Charts. • Manage Facility and IT Asset management Features. • Workflow through Project, tasks and Work Orders and automate the change Request. • Reports Creation on PDF formats on Weekly, Monthly or annual basis for the Various Parameters. 	
Connectivity	HTTP (Modbus & SNMP)	
Sensors	3 x Temperature, 1 x Humidity, 1 x Smoke Sensor	
Fire system	2U Fire Detection and suppression system based on Novec 1230	
CCTV system	CCTV system with 1TB Hard Disk	
Water Leakage Detection system	Water Leakage Detection system in order to identify the Water leakage inside the cabinets.	
Rodent repellent system	Rodent repellent system with 2 Transducer	
Beacon Alarm	Indicator Light with Beacon for the Alarm	
Alarm Lights	Alarm Lights on the Cold Aisle with Red and Blue Indication for the Alarm / No Alarm Indication	
Options	ATS / intelligent PDU... etc	
Weight	150KG	250KG



Powering Business Worldwide

India Head Office

Eaton Power Quality Pvt. Ltd.
2, EVR Street, Sedarpet
Industrial Estate
Pondicherry - 605111
Tel: +91 413 2672000
Enquiries - eatonelectricalindia@eaton.com

Offices Across India

Mumbai

Unit No, 101 & 102 "A" Wing,
1st floor, 215 Atrium,
Andheri Kurla Road, Andheri (East)
Mumbai - 400059
Tel: +91 22 68222100

Delhi

Unit A1 & B1, 3rd Floor,
TDI Centre, Plot No. 7,
Jasola, New Delhi - 110025
Tel: +91 11 45851800

Pune

145, Off. Mumbai - Pune Road,
Pimpri, Pune - 411018
Tel: +91 29 30611886

Bangalore

4th Floor, Prestige Atrium,
Central Street
Bangalore, India - 560001
Tel: +91 80 49012200

Chennai

Eaton Power Quality Pvt. Ltd.
No. 334, Futura Tech Park, Block B,
1st floor, Rajiv Gandhi Salai,
Sholinganallur, Chennai - 600119
Tel: +91-8884053650 / 9381065959
Mob: 9381381414 / 9500679272



Eaton.com/in

© 2023 Eaton Corporation All Rights Reserved India

Toll Free Number: 1800 425 5758, 1800 102 4620

Emergency Number: 893 922 2522

✉ eatonelectricalindia@eaton.com